

THE PRACTICAL ACCESSORIES

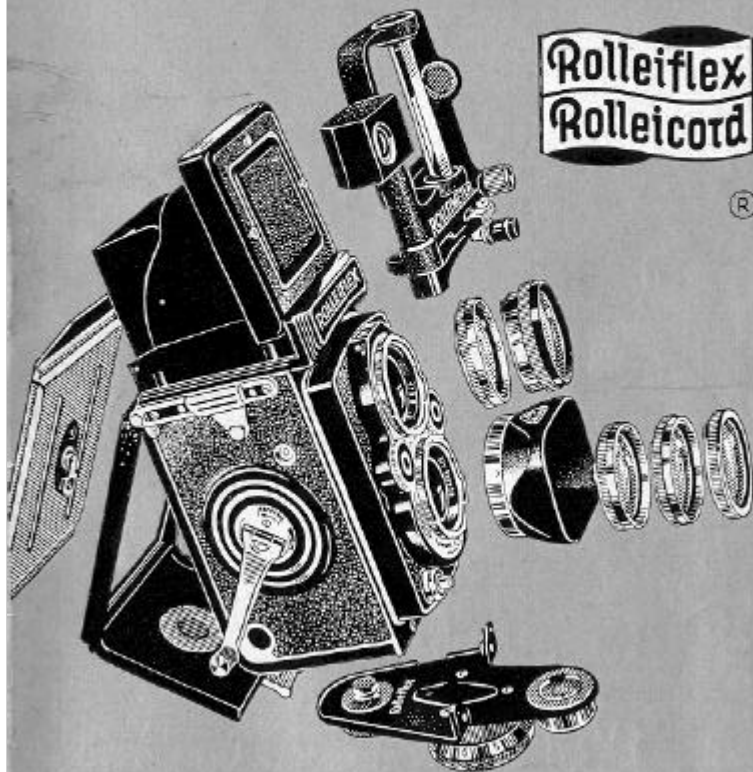

Rolleiflex
Rolleicord

®

FRANKE & HEIDECKE · BRAUNSCHWEIG

Focal Length and Focusing-Range with Rolleinar Lenses

Rolleinar Lenses	—	1	2
Focal Length	75 mm	71 mm	68 mm
Focusing-Range (in inches)	∞ -- $35\frac{1}{2}$ (∞ -- $39\frac{1}{2}$) [*]	$39\frac{1}{2}$ -- $17\frac{3}{4}$ ($39\frac{1}{2}$ -- $18\frac{1}{2}$) [*]	$19\frac{3}{4}$ -- $12\frac{1}{8}$ ($19\frac{3}{4}$ -- $12\frac{1}{8}$) [*]

Field-Size and Scale of Reproduction

Focused Distance	31 $\frac{1}{2}$ in.	19 $\frac{3}{4}$ in.	31 in.
Field-Size (in inches)	22 x 22	13 $\frac{3}{4}$ x 13 $\frac{3}{4}$	8 $\frac{3}{4}$ x 8 $\frac{3}{4}$
Rolleikin	9 x 12 $\frac{1}{8}$	5 $\frac{1}{2}$ x 7 $\frac{7}{8}$	3 $\frac{1}{2}$ x 5 $\frac{1}{8}$
Scale of Reproduction approx.	1 : 10	1 : 6.3	1 : 3.9

Depth of Field with Rolleinar Lenses

Rolleinar		1		2		f / Stop	
Focused Distance (in inches)		31 $\frac{1}{2}$	23 $\frac{1}{2}$	19 $\frac{3}{4}$	15 $\frac{3}{4}$		
Depth of Field (in inches)	from	29 $\frac{1}{2}$	22 $\frac{1}{2}$	18 $\frac{7}{8}$		5.6	Rolleikin ↓
	to	33 $\frac{1}{2}$	24 $\frac{3}{4}$	20 $\frac{1}{2}$			
	from	28 $\frac{3}{4}$	22 $\frac{1}{4}$	18 $\frac{3}{4}$	15 $\frac{7}{8}$	8	
	to	34 $\frac{1}{4}$	25 $\frac{1}{4}$	20 $\frac{7}{8}$	16 $\frac{1}{2}$		
	from	28	21 $\frac{5}{8}$	18 $\frac{1}{8}$	15	11	
to	35 $\frac{3}{4}$	26	21 $\frac{1}{4}$	16 $\frac{7}{8}$			
from	26 $\frac{3}{4}$	20 $\frac{7}{8}$	17 $\frac{3}{4}$	14 $\frac{5}{8}$	16	2 $\frac{1}{4}$ x 2 $\frac{1}{4}$ ↓	
to	38 $\frac{1}{4}$	27 $\frac{1}{4}$	22	17 $\frac{1}{4}$			
from	25 $\frac{1}{4}$	20	16 $\frac{7}{8}$	14 $\frac{1}{4}$	22		
to	41 $\frac{3}{4}$	28 $\frac{3}{4}$	23 $\frac{1}{4}$	18 $\frac{1}{8}$			

Distances are measured from lens board to subject. The figures given in the tables are, for all practical purposes, usable with both 75 and 80 mm lenses. Permissible circuit of confusion = approximately 1/1000 of the focal length of 75 and 80 mm respectively.

3

* Figures given in parenthesis apply to a focal length of 80 mm.



ROLLEIPAR LENSES 1 and 2

Designed for: Correction of parallax when using Rolleinar lenses.

Application: Due to the narrow separation of the lenses, parallax (= the discrepancy between finder image and negative) is very small with Rollei Cameras and has been fully corrected within the normal focusing range from ∞ -- $39\frac{1}{2}$ inches. For close-ups below $39\frac{1}{2}$ inches, this will be accomplished by Rolleipar lenses.

The numbers 1 and 2 correspond to Rolleinar Sets 1 and 2.

For Use: Fasten the Rolleipar to the Rolleinar on the viewing lens. The marking (red dot or engraved double-arrow) must be on top.

Rolleinar 2.8 c (38 mm diameter)

These large diameter close-up lenses incorporate the Rolleipar, built into the Heidosmat-Rolleinar. This is the unit for the viewing lens and should be attached last, with the red dot on top.



ROLLEI FILTERS

Designed for: Correction of color rendition (color sensitivity) of the film: Filters render their won color lighter and the one complementary to it darker in the print.

For Use: Fasten filter to inner bayonet of the taking lens. Increase exposure as indicated by filter factor.

4



ROLLEINAR LENSES 1 and 3

Designed for: Close-ups at distances of less than $39\frac{1}{2}$ inches.

Application: Each set comprises two matched lenses, one each for finder and taking lens: Set 1 covers the range from $39\frac{1}{2}$ --- $17\frac{3}{4}$ ($18\frac{1}{2}$) in.; set 2 from $19\frac{3}{4}$ --- $12\frac{1}{8}$ ($12\frac{1}{2}$) in. (see page 3).

Focusing is accomplished as usual on the ground glass screen.

The depth of field being rather limited at close range, considerable stopping down is advisable with Rolleinar lenses. The depth of field table indicates the most advantageous stops for the $2\frac{1}{4}$ x $2\frac{1}{4}$ and $1\frac{1}{2}$ inch size.

The advantage of a large reproduction should not mislead to indiscriminate shortening of the camera-to-subject distance with close-ups, as this practice would entail danger of distortion. It is less great with objects having a shallow depth of field. For the same reason portrait heads should, if possible, not be taken at distances closer than 40 inches.

Rolleinar Lenses require no increase of exposure.

To Use: Attach one each of the same Rolleinar set in front of both Rollei lenses (Rolleinar 2.8: see page 4): Insert bayonet and turn to the right until it snaps into place.

Lens Accessories with Anti-Reflection Coating

Coating of the lens surfaces materially increase the brilliance of the pictures. To retain this increase in contrast when using lens accessories, these too much be coated. All Rollei optical lens accessories are treated with a hard, abrasion-resistant anti-reflection coating. In addition the coating of each filter is adjusted to enhance the effect of the filter's color and for maximum contrast.

2

Table of Rollei Filters

The filter factors indicate average values which, however, may be changed according to the particular type and make of film used and the light conditions.

Rollei Filter	Use	Filter Factor	
		Ortho	Pan
Light yellow	Landscapes, snow, clouds, Renders yellow and green lighter, blue darker.	3 x	2 x
Medium yellow		4 x	3 x
Light green	Landscapes, snow, clouds, Renders green lighter, red (complexion) and blue darker. For pan emulsions.	3 x	2 x
Green		4 x	3 x
Orange	Hazy distant views. Renders yellow-red lighter, blue darker, distant objects clearer.		3-7 x
Light red	Hazy distant views. Renders red lighter, blue-green darker. Gives stronger effects than Orange Filter.		4-10 x
Light blue	Artificial light. Renders red darker. For ultra-pan emulsions.	1.5 x	1.5 x
U V	High altitudes above 6000 feet. Seascapes. Eliminates ultra-violet rays which reduce contrast.	1.5 x	1.5 x
Infra-Red	Special filter for infra-red emulsions. Transmits dark red above 700 mu and infra-red.	*)	
H 1	UV-Filter, especially designed for long distance color photography. Absorbs ultra-violet rays, subdues predominance of blue and cuts aerial haze in distance shots.	No increase of exposure	

5

*) Exposure depends on the type of emulsion used and must be determined by tests.

AUXILIARY FOCUSING KNOB with Film Indicator

(Not required for Rolleiflex Automats with serial numbers above 1 428 000 and all Rolleiflex 2.8C.)

Designed for: Facilitating sharp focusing under extreme conditions (e. g. in cold weather or when working with gloved hands.) Incorporated in this focusing knob is a mechanical indicator to tell type of speed of film being used.

For Use:

1. Setting for type of film employed: Press down slightly and rotate the front disc inside the milled metal ring.
2. To set for speed of film employed: By turning the grip-bars move the front disc until film speed employed is ascertained.
3. To attach auxiliary focusing knob: Grip the auxiliary focusing knob by the milled rim with two fingers, simultaneously pressing the front disc hard down with the thumb. Attach to the focusing knob of the camera at the correct position of the infinity mark ∞. Remove in the same manner.

EXTENSION HOOD

Designed for: Extending the focusing hood to the normal viewing level.

For Use: Slip extension hood over the opened focusing hood, rounded edge with "breath-guard" toward the operator.

7

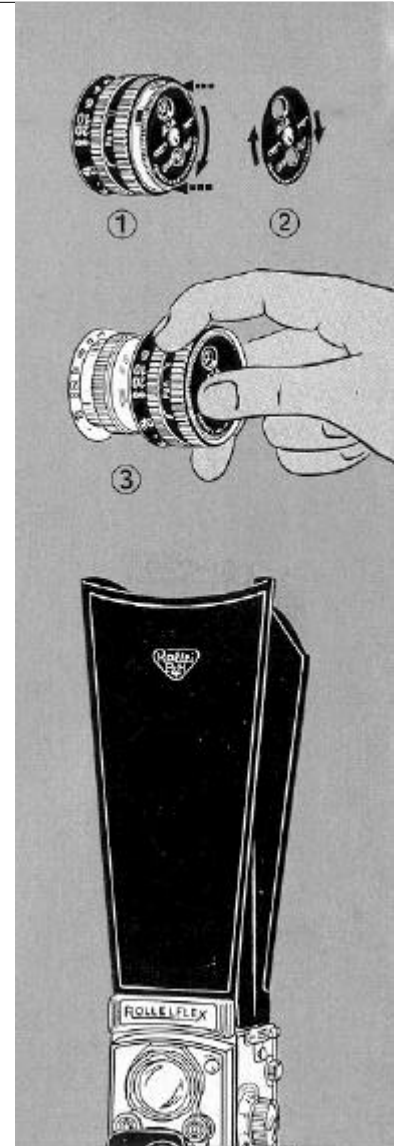

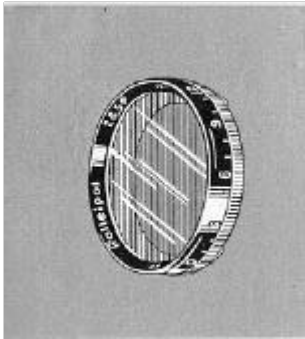

ROLLEIPOL

Purpose: Elimination or subduing of disturbing reflections (glare) from shiny, non-metallic objects or surfaces. Under certain conditions, filter of the blue sky. Especially useful for regulation of the colors (colored reflections) and control of sky tone in color pictures.

Explanation: If the direction of movement of a light beam is imagined to be the axle of a wheel, then the spokes of the wheel correspond to the various plans of oscillation of

the light waves; (i. e., we are looking at the light beam in cross-section). Polarization will reduce the many planes of oscillation to merely one.

Polarization takes place when light waves, striking at certain angle, are reflected by shiny bodies (with the exception of metals). This polarization segment of light can be retained in full or in part by placing the Rolleipol filter across the plane of oscillation: the reflections disappear. (The filter itself has a polarizing effect on the light which passes through it.) Further, since there is also polarized light in the blue sky, this can be eliminated: the use of the Rolleipol filter results in subdued (darkened) sky portions.

Not all reflected light is polarized. If reflections are to be eliminated, 1. the filter must be turned (on its optical axis) in the direction of the vibrations as required, and 2. the camera position must be changed to gain the best effect. This is attained when the beam of light striking the reflecting body and the line of camera view form an angle of 60-74°, (varies according to material of the subject).

Application: 1. For eliminating or subduing disturbing reflections when photographing reflecting objects (polish, porcelain, painted and lacquered finishes, etc., -- reproduction of textures and materials), when photographing glass surfaces and the surface of water (the reflecting surfaces become transparent), 2. for filtering sky when photographing landscapes: the blue sky is darkened by absorption of the polarized light it contains. The fact may be observed in advance by looking through the filter. -- Required increase of exposure: approximately 3X.

For Use: Fasten the Rolleipol filter on finder lens (red dot on the top) and rotate the front ring of the Rolleipol until the desired effect is obtained on the ground glass. Note the white number marking and transfer to the taking lens in the same position.

8



ROLLEIGRID LENS

Purpose: To brighten the ground glass screen image at the edges.

To Install: Place the Rolleigrid with the narrow front edge against the ground glass screen, let it slide forward under the retainer tab, then drop the rear end and fasten by means of the push-button at the rear of the focusing hood (see also p. 15, B 5). The condenser must be placed on the ground glass with the grooved side down.

To Remove: Turn the camera over, push the button, letting the Rolleigrid fall out of the hood.

To Clean Rolleigrid: Use a wad of cotton and a mild soap and water solution.

LENS HOOD

Designed for: Protection of the lens from extraneous light and to shield it from rain, snow or spray at watersports events.

For Use: Fasten lens hood to outer bayonet of the taking lens.

6

ROLLEISOFT LENS 0 and 1

Purpose: Softening of super-critical definition producing striking fluffy halo-effects, especially with back-lighting.

Explanation: The taking lens of the Rollei gives super-critical definition required for the majority of exposures. If, occasionally, softer definition is desired (e. g. for portraits and certain dramatic effects) this is obtained by attaching the Rolleisoft Soft Focus Lens in front of the lens.

The Rolleisoft lens consists of a plane parallel glass disc with a few concentric ground-in grooves. While otherwise the lens permits only sharpness of softness through adjustment of the focus, the Rolleisoft lens obtains both simultaneously: Between these grooves the rays of light pass unimpeded to the film and produce a sharp impression, i.e., the basis of the image. At the grooves, however, the light rays are diverted with the result that an additional image of slightly softer definition is superimposed. Both together produce the soft focus effect: The exposure shows fluffy softened contours and sunny halo-lights; distracting fine details receded and the total impression of depth definition is improved. By means of the Rolleisoft the Rollei lens becomes a soft focus lens.

Application: Best results are obtained by using the entire surface of Rolleisoft, i.e., with full aperture. With Rolleisoft 1 (with increased number of grooves) it is permissible to stop down to f 5.6. Smaller apertures tend to decrease the soft focus effect.

Rolleisoft 0 is used for weak soft focus effect: primarily for strong contrasts of light and glittering objects, i.e., chiefly for back-lighted subjects. Rolleisoft increases the plastic, sunny characteristic of back-lighted pictures. Speed and local length remain unchanged. Generous exposures increase the halo-effect. The ground glass screen shows full focused sharpness when using Rolleisoft lenses. The Rolleisoft effect can be judged at any time on the ground glass screen by placing the Rolleisoft in front of the finder lens.

For Use: Fasten Rolleisoft to inner bayonet of the taking lens.



PLATE-ADAPTER

Designed for: Single 2-¹/₄ X 2-¹/₄ inch exposure on 2-¹/₂ X 3-¹/₂ inch plates of sheet-film. A desirable facility of the use of special emulsions, immediate or individual processing and such special tasks as studies of portraiture, trick-photography, reproductions, technical tests, etc.

The outfit consists of:

1. Special Adapter Back
2. 3 Plate Holders
3. Focusing-Screen Holder
4. Leather Case for 2 Plate Holders.

Also available:

5. Cut-Film Sheath.

All parts are available separately. Focusing is done as usual on the reflex focusing-screen and only in special cases (f. e. when using two Rolleinars combined, or utilizing the picture area to the fullest extent) on the adapter focusing-screen.

A. Attaching the Adapter Back

1. Remove take-up spool from camera.
2. Take off camera back.
3. Attach adapter back (without plate holder!).

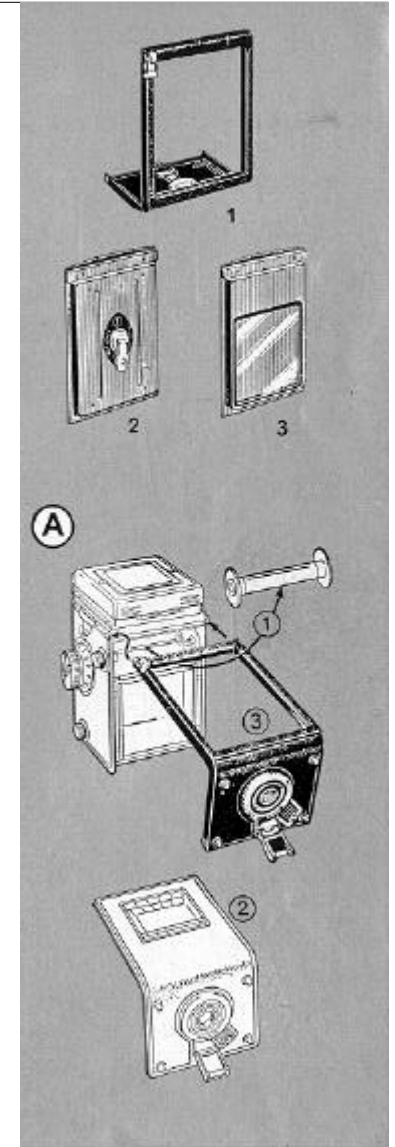

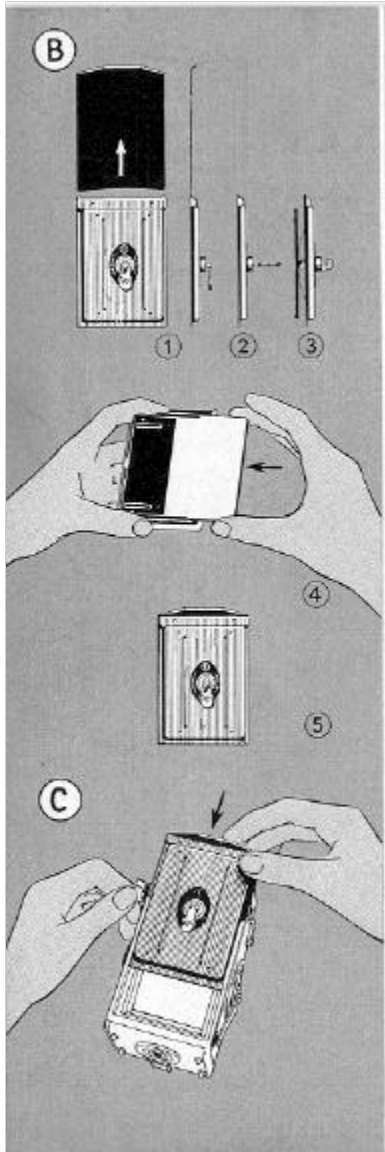

B. Loading the Plate-Holder

1. Withdraw slide.
2. Lift up locking lever on back of holder and
3. let it slip inside after a quarter turn. Spring action pushes out plate-carrier.
4. Slide plate (or cut-film with cut-film sheath placed underneath) into carrier.
5. Retract lever, lock by a quarter turn and fold down (the number remaining visible). Close holder by reinserting slide.

Note: Conserve push-strip by always removing slide from empty holders before storing away.

C. Inserting the Plate-Holder

Swing catch out of way and slide holder down the lateral grooves of the adapter back. The catch locks holder against unintentional removal.

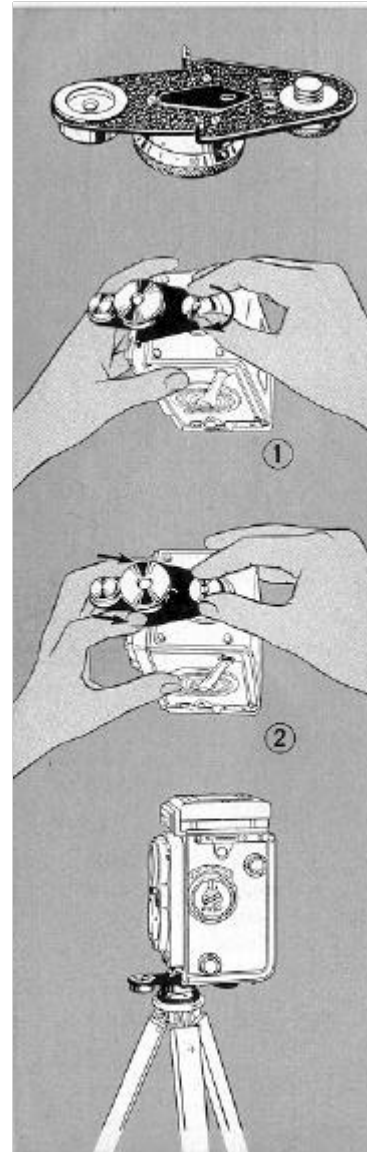

PANORAMA HEAD

Designed for: Taking of panoramic views composed of 10 individual pictures.

For use:

1. Screw panorama head at first only lightly into a tripod socket.
2. Match pins and sockets of panorama head and camera, then press together.
3. Tighten screw firmly
4. Screw in tripod.
5. Level off horizontally by centering bubble of spirit level.
6. For partial panoramic views start at the left, as the panorama head may be turned clockwise only.
7. For each successive exposure turn camera to the next click-stop number engraved on the base of the panorama head. 10 exposures give a panoramic view of 360°. Lateral overlapping of pictures ensures perfect joints.

D. Exposure

1. Withdraw slide.
2. Lift up lever and let it slip inside after a quarter-turn. The plate moves into the focal plane by spring action.
3. After the exposure, retract lever first, then fold upward after a quarter-turn. The letter "B" indicates that the plate has been exposed.
4. Only now reinsert slide.

E. Focusing-Screen Holder

1. Insert the closed holder.
2. Withdraw slide. Spring action presses focusing screen automatically into the focal plane.
3. Reinsert slide first, and then remove holder.

F. Note

1. Shutter cocking as usual: with Rolleiflex, normal swing of the crank.
2. For use of plate adapter with Rolleicord IV the double exposure device must be disengaged in order to unlock shutter.

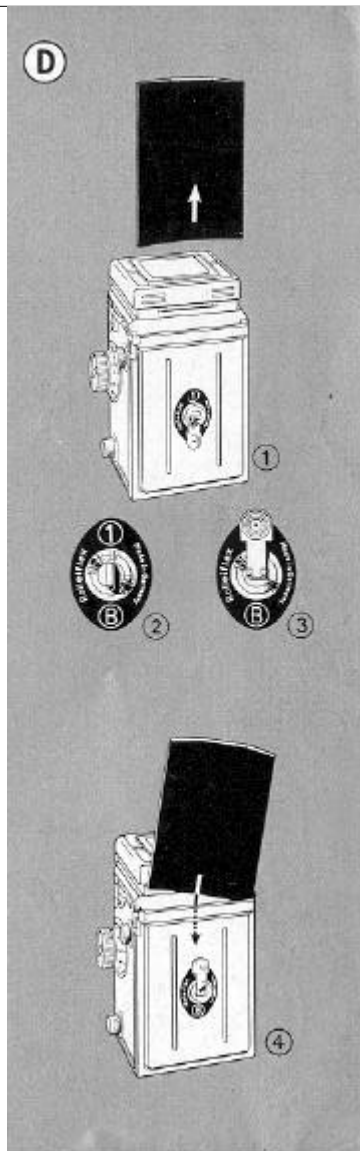

B. Assembling the Rolleikin

1. Adjust film pressure plate by a sliding movement, pressing down at the same time, thereby bringing the inscription "24 x 36 mm (1 x 1-1/2 in.)" into view.
2. Pull counter-knob, fit-in take-up spool on the right and insert completely.
3. Rewind-Parts: Screw extension-spindle on rewind-knob by rotating the latter. Snap inner spool-knob over opposite spool bearing pin, (slipping the metal tongue between the rollers of the film-feed when using a Rolleiflex).
4. Inserting the film guide frame: Press spring actuated clamp-bar at an acute angle (as shown) against the bottom of the film gate and insert completely. To remove: Push frame downward (against the clamp-bar) and lift out.
5. First insert forward edge of focusing screen mask under the grip, snap down and secure by pressing the retaining device. Be sure the mask is properly centered inside the ground glass frame.

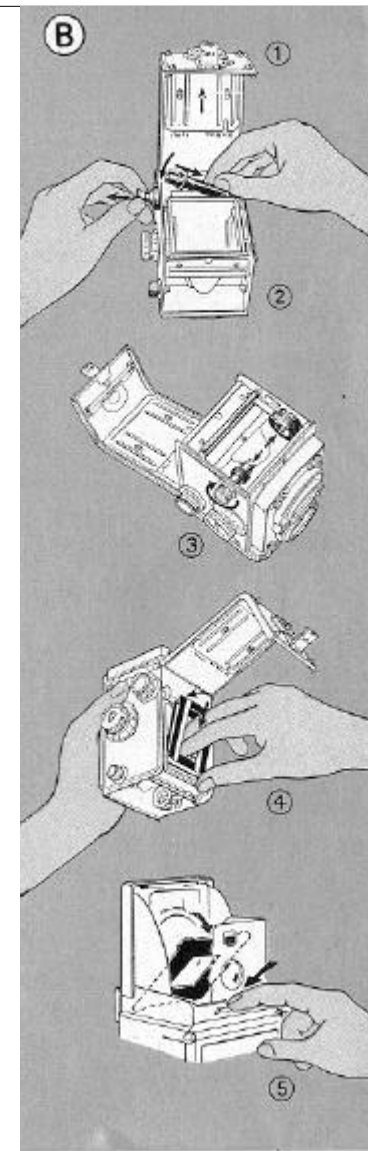

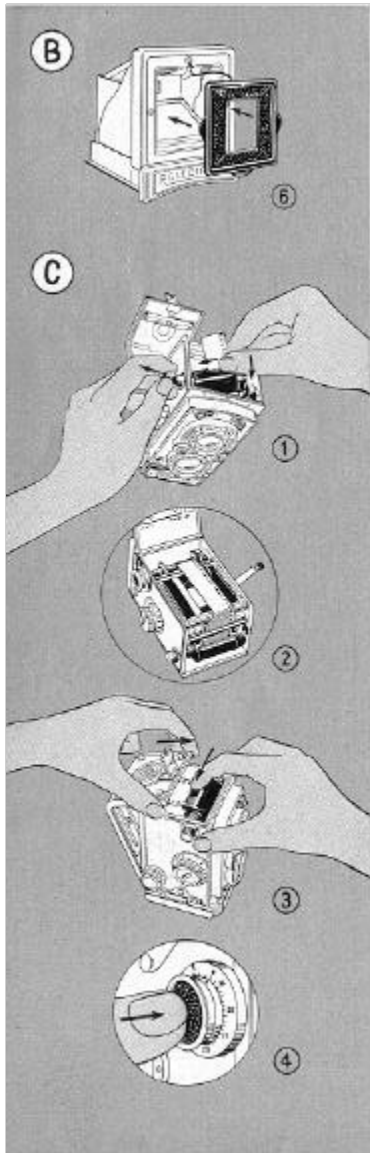

6. Insert the frame-finder mask underneath the button above the frame-finder in such a way that the edge (marked with a white dot) is pushed-in first, then press the two lateral fixing buttons into position.

C. Loading

1. Open camera back, pull rewind-knob, fit in film cartridge on the left and then insert fully.

2. Introduce film lead (which -- in the Automatic Rolleiflex -- first passes through the film-feed rollers) into the double slit of the take up spool, letting it touch on the right. Tighten up by giving spool a short turn.

3. Make sure the mouth of the cartridge points straight ahead in line with the tightened film lead, then close back.

4. Press-and-release counter-knob until the red dots of the Rolleikin counter face each other. Disregard counter for 120 film completely.)

5. To set counter for the first exposure: Advance counter dial by No. 1 by actuating film transport three times (see page 17).

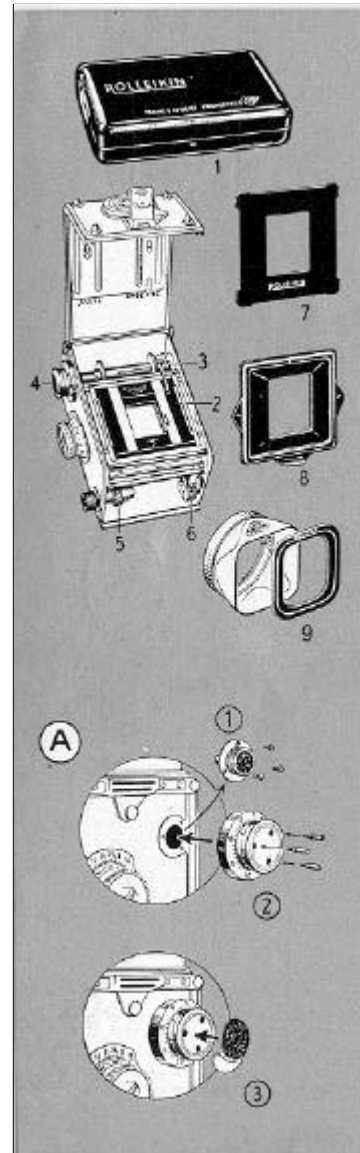

ROLLEIKIN 2

Designed for: Taking up to 36 exposures 1 x 1-1/2 inches on 35 mm film. Ideal for series of pictures and color photography on miniature film.

The attachment consists of:

1. Case
2. Film Guide Frame
3. Take-up Spool
4. Exposure-Counter-Knob*
5. Extension-Spindle for Rewind-Knob (two types, for previous and new Rolleiflex models).
6. Inner Spool Knob
7. Focusing Screen Mask
8. Direct View Finder Mask
9. Lens Hood Mask.

Applicability of Rolleikin 2: Fits Rolleiflex above numbers 1 100 000 and Rolleicord above numbers 1 137 000. (The combination back for two pictures sizes was originally not provided with the first camera series, but can be ordered additionally). -- Earlier Rollei models use Rolleikin 1 (with special back).

A. Installing the Counter-Knob*

(The exposure-counter-knob) accepts 35 mm and 120 film. Your dealer will gladly take care of the fitting for you.)

1. Remove the top film-knob by unscrewing the 3 counter-sunk screws.
2. Fasten counter-knob tightly by means of the three screws supplied.
3. Remove protective lining from gummed insert and paste it on the counter-knob.

D. Film Transport

1. Press-and-release counter-knob before actuating film transport. The exposure counter advances automatically to the next number.
2. Advance film as usual to the stop.

E. Rewinding

1. After the last exposure has been made, rewind film by keeping counter-knob pressed down.
2. simultaneously rotating rewind-knob clockwise.

F. Note

1. The rewind also permits the removal of only partially exposed films. In order to prevent the film lead from slipping into the cartridge when rewinding, be sure to thread the film backward, i.e., against the winding direction into the double-slit of the take-up spool when loading. When reloading a partially exposed cartridge, advance film two frames beyond the last exposure (skipping one frame for safety).
2. Always adjust film pressure plate properly (see B 1)! (A sure sign of incorrect adjustment when using the Rolleikin: Camera back will not close all the way.
3. When using the Rolleikin it will be convenient to keep the empty roll film spool in the Rolleikin case (next to the insert for the Rolleikin take-up spool) since it will be required the next time roll film is to be used.
4. Shutter cocking as usual: with Rolleiflex, normal switch of the crank.
5. Double exposure device is in operation in the Rolleiflex and can not be disengaged when using the Rolleikin. With Rolleicord IV it must be disengaged in order to unlock the shutter.

17

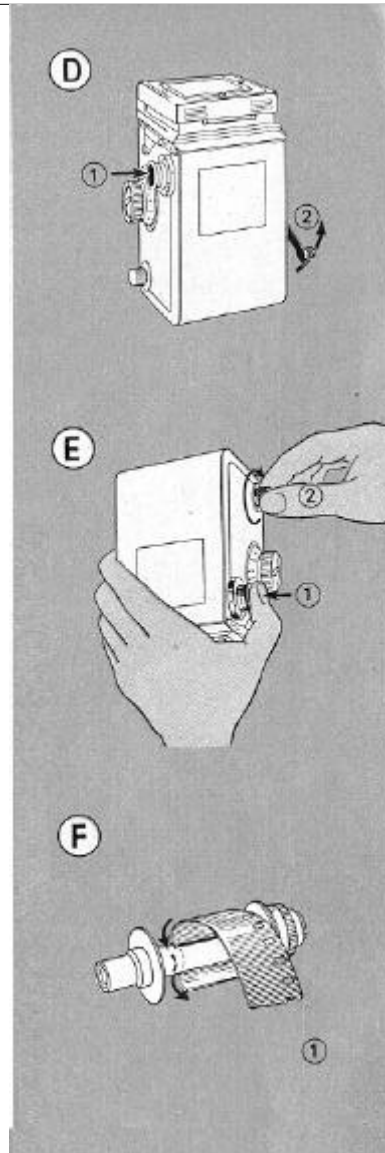

A. Adjustment to focal length

(This is done before attachment to the camera and is required so that the Rolleimeter and camera will agree even at close distances, such as three to five feet. See note 2.)

For this adjustment a special plate is provided, suitable for cameras calibrated in either feet or meters. By its use the relationship between infinity and the close distance readings of the focusing knob scale may be observed and the Rolleimeter's actuating arm properly adjusted.

1. Place the adjustment plate over the focusing knob and line up the infinity marks, note whether meters or feet.
2. Note the figure on the adjustment plate which is directly opposite the marker for the closest focusing distance of the knob. Rolleiflex Automats will have 3 feet as this distance.
3. Swing actuating lever H outward and loosen the coin-slotted screw a.
4. Move the slide to the previously observed adjustment plate figure and tighten screw a.

19

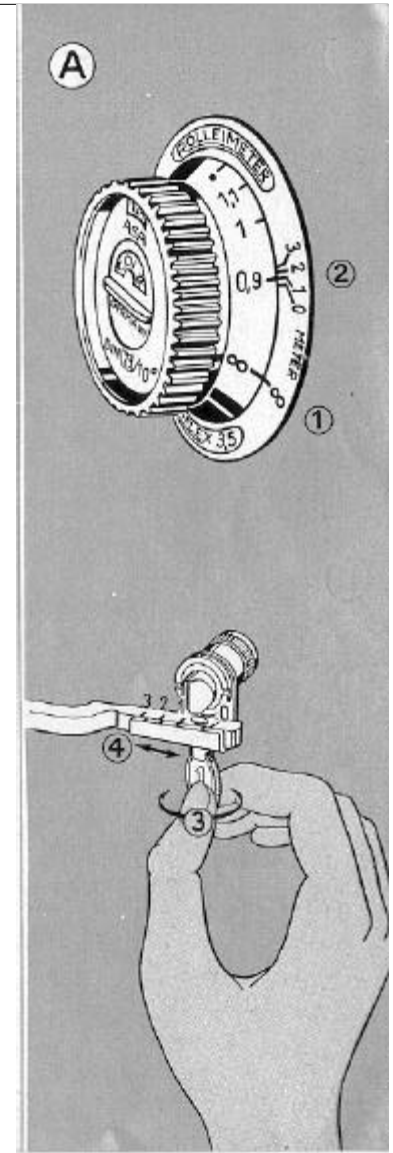

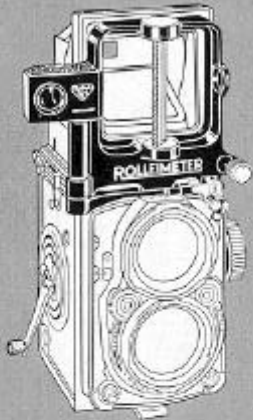
B

B. Attaching Rolleimeter to Camera

1. Set camera at infinity (∞).
2. Turn mounting screw **c** counter-clockwise until it stops.
3. Hook the Rolleimeter over the left edge of the nameplate and push it back so that the right side fastener can be engaged. Be sure that the actuating lever rests on the camera's movable front panel.
4. Hold Rolleimeter firmly in position with thumb and turn screw **c** clockwise until tight. Removal is effected by complete counter-clockwise turning of mounting screw **c** and lifting off.

C. Adjustment to Infinity

(this is done after mounting Rolleimeter)

1. Set focusing knob to infinity (∞), open focusing hood and direct view finder.
2. Unscrew protective cap **d** and remove.
3. Select and observe some object (building, tree, lamp post, etc.) at least 600 feet distant. Looking at the focusing spot in the glass rod, run screw **b** until the outlines of the two images coincide and the images become one.
4. Replace protective cap **d**, tighten, and double-check the coincidence of the two images. This adjustment should occasionally be rechecked.

20

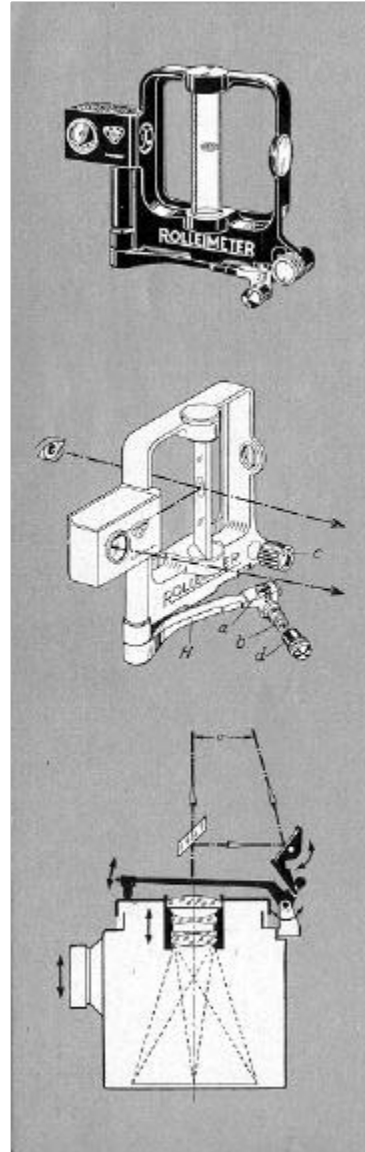
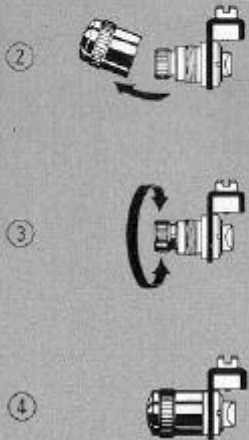
C

ROLLEIMETER

Purpose: An optical coupled range finder for use with the direct view finder of the Rolleiflex: particularly suitable when shooting sports or flash pictures in poor light.

Description: The Rolleimeter uses the superimposed image principle and is actuated by and coupled to the moving front panel of the camera. It is attached to the nameplate directly in front of the direct view finder. A vertical glass rod with focusing spot for the two images can be seen when looking through the finder. Focusing the camera by superimposing the two images so that the outlines exactly coincide insures sharp focus. Framing and focusing are accomplished while looking through the finder, without moving the eye from one position to another. Before using the Rolleimeter two simple adjustments are required:

1. A one time adjustment of the actuating lever (screw **a**) to suit the focal length of the lens employed.
2. Adjustment of the lever button (screw **b**) so that the range finder indicates sharp focus at infinity (∞) when the camera is in focus at the same distance. This adjustment should be re-checked from time to time.

18

D. To use

Locate the object on the focusing spot of the Rolleimeter's glass rod, as seen through the open direct view finder, and turn the camera's focusing knob until images coincide. The Rolleiflex will be sharply focused to the exact distance of the object selected.

E. Note

1. For use with Rolleiflex 2.8C (80 mm lens) the Rolleimeter C is supplied together with suitable adjustment plate.
2. Proper adjustment to focal length can be effected easily in the case of earlier Automats (whose knobs are not the right size to permit use of the adjustment plate) by means of the ground glass screen image. Following is the proper method: First, make the infinity (∞) adjustment. Then focus the camera accurately on a suitable vertical object at the closest distance. Check the Rolleimeter and if the two images do not coincide, remove it and loosen screw **a**. Relocate the slide at some point in the adjustment range, between 0 and 3, where the images do coincide. Tighten screw **a**. Check the setting again and finally double-check the infinity adjustment. Correct if necessary (see A).

21

Lens Accessories should be attached in the following order:

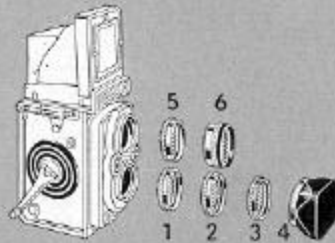

Taking lens:

1. Rolleinar
2. Rolleisoft
3. Filter or Rolleipol
4. Lens Hood

Viewing Lens

5. Rolleinar
6. Rolleipar

if two or more supplementary lens accessories are to be used, they must be attached in this order. Rule: Rolleinar always first (lens to lens) and filters last. *

When ordering, please note!

To insure obtaining correct accessories for use with your Rollei, **please specify camera model, lens and serial number**

The connector **f** is for use with the supplementary flash unit Rolleiflash-Comb.

4. Lamp ejection: by pressing ejector button **g** -- the lamp is forcefully ejected.

C. Changing Batteries

1. Loosen screw ring **h** slightly, open case upwards and remove. -- To close the case: First attach cover with retaining pin on case, close tight, tighten screw ring **h**.
2. Changing the battery: Important! The + pole must always point toward the test lamp! Wrong insertion of battery would damage the condenser. Insertion of fresh battery (flat cell hearing aid battery 22.5V): press back contact spring **i** with the battery, snap battery in.
3. Changing test bulb: As replacement for detective lamps, press same type 6 V glow lamp (0.05-0.07 amperes) between contact springs.

D. Flexible Arm

The flexible holding arm can be unscrewed from the case when the Rolleiflash attachment is to be fastened directly onto a tripod by the base thread. To replace holding arm: turn back screw ring **k** on holding arm as far as it will go, screw arm into case (up to correct position of bayonet ring) and secure by turning screw ring **k** clockwise.

23

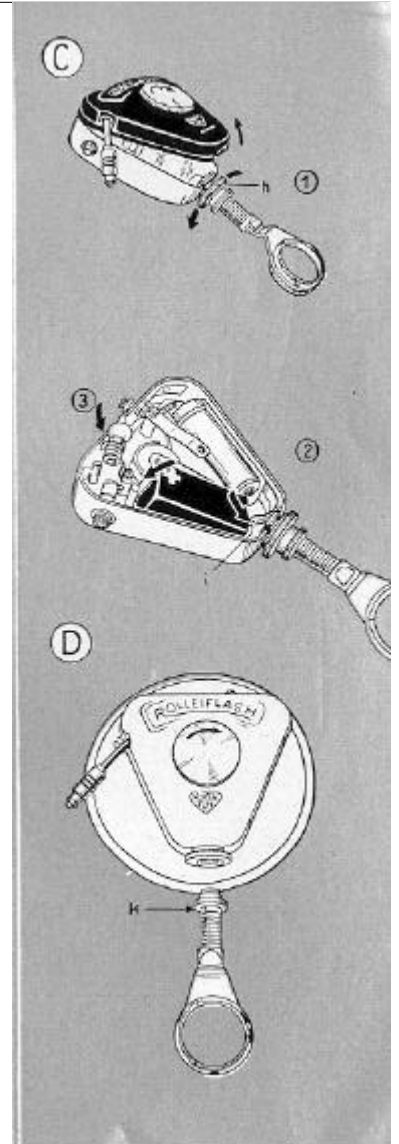

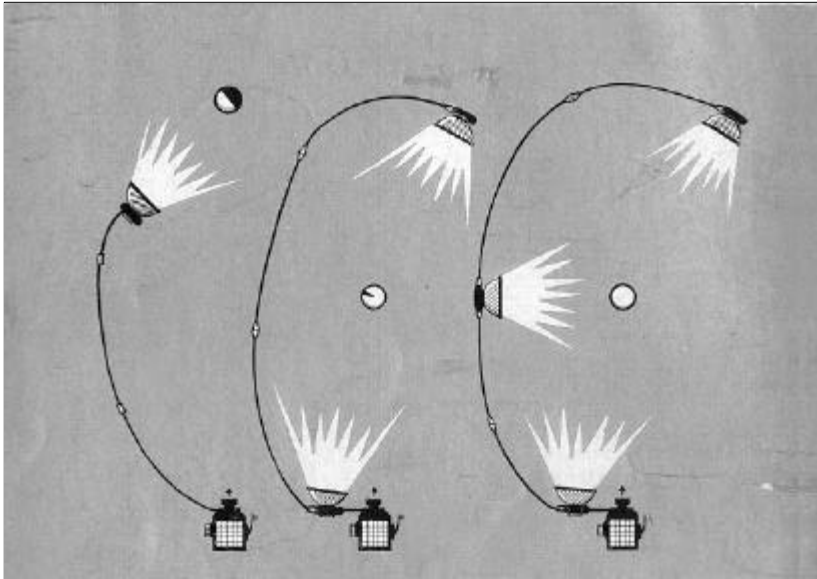

When using more than one lamp, start with insertion of lamp in main unit at camera.

To avoid unnecessary drain of the battery: Insert flash lamps just before exposure and eject immediately afterwards.

E. Rolleiflash -Comb.

Screw the cable end connectors to the Rolleiflash and Rolleiflash-Comb. The Rolleiflash Comb. can either be hand-held or fastened to a tripod by the socket provided. The second connector is for an additional Rolleiflash-Comb., if used. A total of three lamps may thus be fired simultaneously. Lamp distance can be extended to 33 feet by means of 10 foot extension cords of two types, for Rolleiflash and Rolleiflash-Comb.

F. To attach Rolleiflash Extension Cords

Unscrew protective cap to limit, insert flash cord plug and tighten cap down over plug.

pa5401_991002.pdf

E 0654 E.A.Co.

Printed in Germany

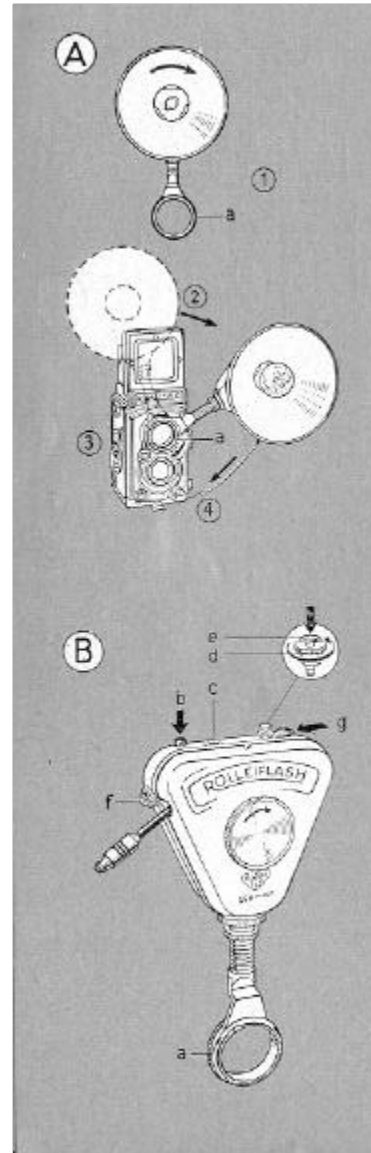

ROLLEIFLASH

Purpose: Synchronized flash exposures with the Rolleiflex.

Applicable Flashbulbs with bayonet base (swan).

B-C principle (Battery-capacitor firing).

A. Mounting Rolleiflash

1. Fasten reflector on case by turning it clockwise in bayonet.
2. Fasten holding arm to bayonet of the viewing lens and
3. Secure by turning lock ring **a** clockwise. Before removing: first loosen lock ring by turning counter-clockwise.
4. Pull out the cable and plug it into the flash socket on the camera. To roll up the cored: use turn-knob (on cover of case).

B. Exposure

1. Insert flash lamp as far as necessary to seal in the bayonet socket.
2. Test circuit: Press test key **b** -- brief flash of the test lamp **c** indicates positive firing of flash lamp.
3. Synchronized flash-firing: by releasing camera shutter (see directions for using camera).

Open-flash method (Firing by hand contact in making time exposures): loosen safety screw ring **d**, press hand contact **e**. Always secure hand contact when not in use!